



*Remember to
register your
air purifier at:*

www.surroundair.com/register/

INSTRUCTION MANUAL



Multi-Tech 8500 Air Purifier

HEPA ● Activated Carbon ● Germ-Killing UV Lamp
Photocatalytic Oxidation ● Ionizer

Toll Free: 888.812.1516 ● Web: surroundair.com
Email: support-team@surroundair.com



WARNINGS

Failure to comply with the warnings listed below may result in electric shock or serious injury.

This product should be used only in accordance with the specifications outlined in this manual. Usage other than what has been specified here may result in serious injury.

When using electrical appliances, basic precautions should always be followed to reduce the risk of fire, electric shock and injury to persons, including the following:

- Read all instructions before using appliance.
- **IMPORTANT** - This appliance has a polarized plug (one blade is wider than the other). To reduce the risk of electric shock, this plug is intended to fit in a polarized outlet only one way. If the plug does not fit fully in the outlet, reverse the plug. If it still does not fit, contact a qualified electrician. Do not attempt to circumvent this safety feature.
- To avoid fire or shock hazard, plug the appliance directly into a proper AC electrical outlet.
- Keep the cord out of heavy traffic areas. To avoid fire hazard, **NEVER** put the cord under rugs, or near heat registers, radiators, stoves or heaters.
- To protect against electrical hazards, **DO NOT** immerse in water or other liquids. Do not use near water.
- Children cannot recognize the hazards associated with the usage of electrical appliances. For this reason, always supervise children when they are near the unit.
- Always unplug the air purifier before moving it, opening the grill, changing filters, cleaning or whenever the air purifier is not in use. Be sure to pull by the plug and not by the cord.
- **NEVER** drop or insert any object into any openings.
- **DO NOT** run cord under carpeting.
- **DO NOT** cover cord with throw rugs, runners, or similar coverings.
- **DO NOT** route cord under furniture or appliances. Keep the cord out of traffic areas and where it will not be tripped over.
- **DO NOT** operate any appliance with a damaged cord or plug. If the fan motor fails to rotate after the appliance malfunctions, or if it has been dropped or damaged in any manner, contact Surround Air Customer Service for assistance.
- Use this appliance only for intended household use as described in this manual. Any other use not recommended by the manufacturer may cause fire, electric shock or injury to persons.
- **DO NOT** use outdoors.
- **DO NOT** place anything on top of unit.
- **NEVER** block the air openings, grills/outlets or place on a soft surface such as a bed or sofa. This could cause the unit to tip over, blocking the air intake or outlet opening.
- **DO NOT** attempt to repair or adjust any electrical or mechanical functions on this unit. Doing so will void your warranty. The inside of the unit contains no user serviceable parts. All servicing should be performed by qualified personnel only.
- **WARNING:** To reduce the risk of fire or electric shock, do not use this fan with any solid-state speed control device.

TECHNICAL SPECIFICATIONS

| | |
|----------------|---|
| Rated Voltage: | AC 120V, 60Hz |
| Rated Power: | 55W |
| Noise Level: | 30dB (L), 40dB (M), 50dB (H) |
| UV Light: | Wavelength: 254 nanometers (germicidal wavelength) Lamp life: Approx. 30,000 hours (roughly 3.5 years) |
| Weight: | 10 lbs. |
| Dimensions: | 15.5" (L) x 5.75" (W) x 16.75" (H) |
| Coverage Area: | Up to 500 sq. ft. |

PRODUCT STRUCTURE

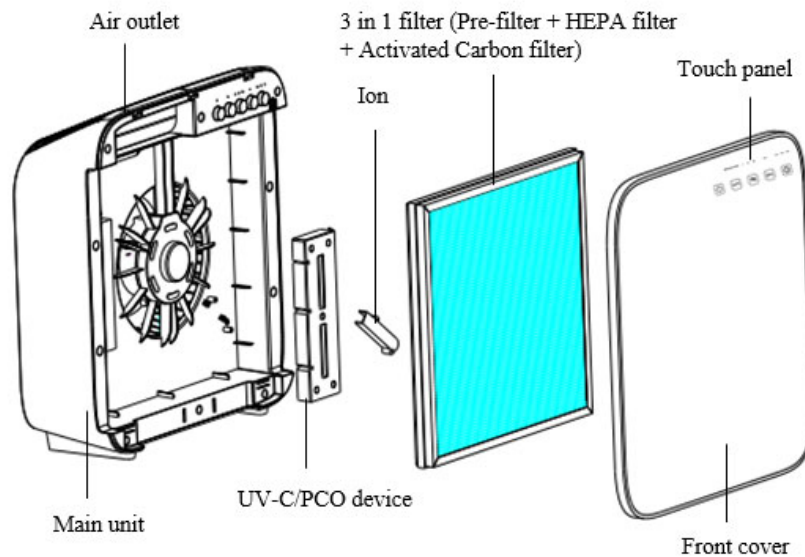

AIR CLEANING SYSTEM

The Multi-Tech 8500 offers multiple air-cleaning technologies to remove nearly all types of airborne contaminants.

PRE-FILTER: Captures larger dust and allergen particles, prolonging HEPA and Carbon filter life.

HEPA FILTER: The most effective type of filter for capturing fine dust and allergen particles, such as pollens, dust mites and mold spores.

ACTIVATED CARBON FILTER: The most effective type of filter for removing chemicals, gases, odors and smoke.

UV-C LIGHT: Destroys micro-organisms such as germs, viruses, bacteria and fungi.

PHOTOCATALYTIC OXIDATION: Effectively reduces chemicals, bacteria and odors.

IONIZATION: Circulates trillions of air-cleaning ions, settling pollutants out of the air and improving the efficiency of the filters.

OPERATING INSTRUCTIONS

BEFORE OPERATING THE AIR PURIFIER:

1. Carefully remove your air purifier from the box and plastic bag.
2. Select a firm, level and flat location for the air purifier.

*For proper air flow, locate the unit at least 1 foot from any wall or furniture.

*Make sure none of the grills are blocked.

3. Plug the power cord into an AC outlet of proper voltage.

IMPORTANT: When moving the air purifier, always lift the unit by the carrying handle located on back.

OPERATING THE AIR PURIFIER

REPLACE FILTER I II III UV-C/Ion 2H 4H 8H

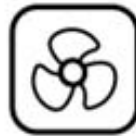

1. "POWER" BUTTON:

Press this button to turn on or switch off the unit.



2. "AUTO" BUTTON:

Press this button to activate AUTO function. In AUTO function, the fan speed will adjust according to the air quality, based on the continuous readings of the pollutant sensor.

Note: When the REPLACE FILTER light begins to flicker, press and hold this button to reset the filter change indicator.



3. "SPEED" BUTTON:

The fan speed of the unit can be adjusted when the unit is in operation (I=Low; II=Medium, III=High). Each time that you press the (SPEED) button, the speed is adjusted from L (low) to M (medium) to H (high) and back to low again.



4. "UV-C" BUTTON:

Press this button to turn the UV/Ion/Photocatalytic Oxidation functions on and off. "On" by default.



3. “TIMER” BUTTON:

- 1) By pressing this button, the purifier can be timed to operate for intervals of 2 hours, 4 hours and 8 hours, stopping automatically when the selected operating time has elapsed.
- 2) Press this button (Timer) to select the required operating time. A warning light automatically indicates the remaining operating time.
- 3) To select the continuous operating mode, press the button repeatedly until the indicator light goes off.



Important Note: When the unit is not in use, switch it off and unplug it.

INSTALLING & REMOVING FILTERS

FILTER REPLACE INDICATOR

If the POWER light begins to flicker continuously, it is time to replace the filter. Replace the filter according to the directions then press the AUTO button and hold it for 5 seconds to restart the system. The light will stop flickering.

*Combination Filter will last approximately 12 months. Change more frequently for optimal performance.



1. Open the front cover from the bottom.
2. Remove the combination filter by pulling the two strips on either side.
3. Insert new Combination Filter into the unit. Consult the strips on the filter for correct installation direction.
4. Reattach the extra Pre-filter to the Combination Filter.
5. Reattach the Front Cover of the unit and securely latch into place.
6. Press and hold AUTO Button for 5 seconds to reset the Filter Change Indicator.

CLEANING & MAINTAINING THE COMBINATION FILTER

The air purifier should be cleaned at least once every month and the outer Pre-Filter/Activated Carbon Filter attached to the HEPA Filter should be cleaned every month. More frequent cleaning may be required depending on environmental conditions.

PRE-/ACTIVATED CARBON FILTER

Clean with the brush attachment of your vacuum cleaner. This will remove lint and dirt.

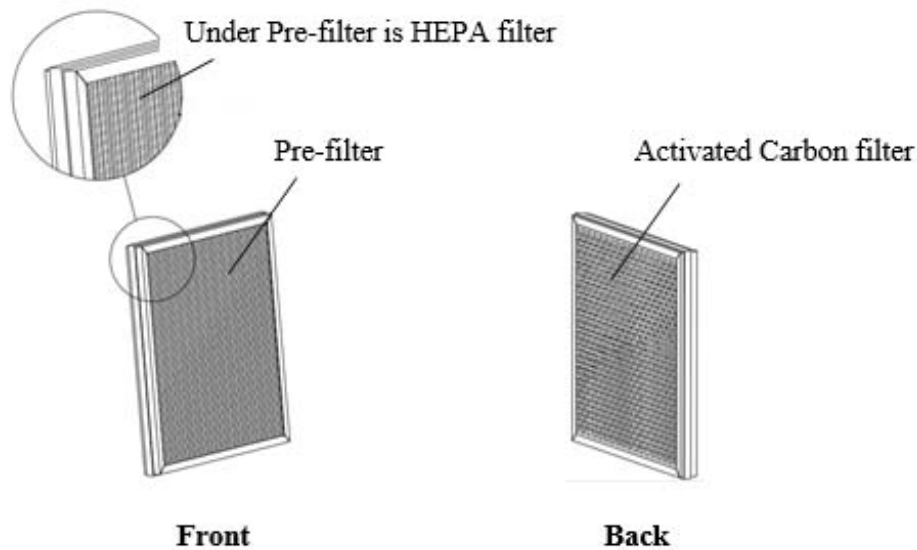

NOTE:

-Only the **Extra Pre-filter** is washable (with water).

-The Combination Filter is a one filter system. The multiple layers include: the Pre-Filter, Activated Carbon Filter and HEPA Filter.

AIR PURIFIER

Use a clean, dry, soft cloth to wipe the external surface of the unit.

NOTE: DO NOT stick any foreign objects or your fingers inside of the unit.

CAUTION: DO NOT use gasoline, benzene, paint thinner, harsh cleaners, etc. on and/or in the unit while cleaning, as these substances will damage the product.

NEVER use alcohol or other solvents.

MINI TROUBLESHOOTING GUIDE

Before carrying out any of the following service checks, unplug the unit from the outlet.

| | |
|-----------------------|---|
| Insufficient air flow | Check that the filters are clean Check for any obstructions in the air inlet and outlet |
| Unit will not start | Check the power supply and electric fuses. Check that the Front Cover is latched firmly in place. Check that the Filter is firmly in place. |
| Excessive noise | Check for any foreign objects in contact with the fan. The Combination Filter may be clogged and ready for replacement. Uneven positioning. |

Warranty

What is covered: All parts defective in material and workmanship.

Exclusions: Regular replacement parts such as air filter cartridges and UV lamps.

For how long: Three years from purchase date.

What we will do: Repair or replace any defective parts.

What you must do:

1. Go to the following web address and fill out the form located on this page:
www.surroundair.com/return-form/
2. After receiving your shipping instructions, pack the product in its original carton, and in the same manner in which you received it, or as identical as possible.
3. Include proof of purchase inside box.
4. Label and ship the unit, freight prepaid, to the address provided.

Other Conditions

The provisions of this warranty are in lieu of any other written warranty, whether express or implied, written or oral, including any warranty of merchantability or fitness for a particular purpose. The manufacturer's maximum liability shall not exceed the actual purchase price paid by you for the product. In no event shall the manufacturer be liable for special, incidental, consequential, or indirect damages. This warranty does not cover a defect that resulted from improper or unreasonable use or maintenance, accident, improper packing, or unauthorized tampering, alteration, or modification as determined solely by us. This warranty is void if the label bearing the serial number has been removed or defaced.

90-Day Replacement Policy

If any part requires repair during the first 90 days after receiving your air purifier, due to manufacturer defect, then Surround Air will replace it with a new machine.

What you must do:

1. Go to the following web address and fill out the form located on this page:
www.surroundair.com/return-form/
2. After receiving your shipping instructions, pack the product in its original carton, and in the same manner in which you received it, or as identical as possible.
3. Include proof of purchase inside box.
4. Label and ship the unit, freight prepaid, to the address provided.

Spare Parts

1. HEPA/Activated Carbon Air Filter Cartridge
2. Germicidal UV Lamp

Where to Buy

Surround Air

<http://www.surroundair.com>

Toll Free: 888.812.1516