

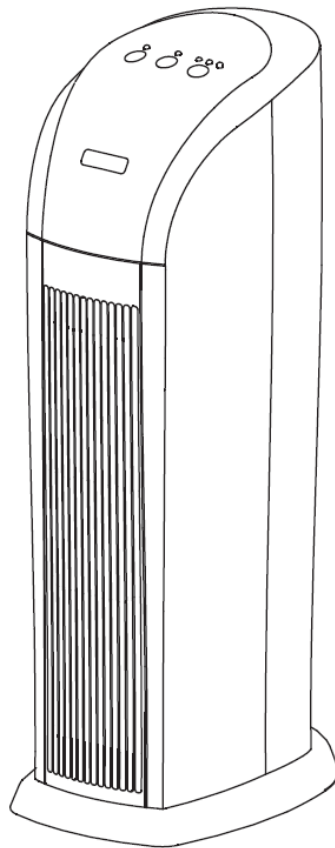

*Remember to  
register your  
air purifier at:*

[www.surroundair.com/register/](http://www.surroundair.com/register/)

# INSTRUCTION MANUAL



## T1000 Air Purifier

HEPA ● Activated Carbon ● Germ-Killing UV Lamp  
Photocatalytic Oxidation ● Ionizer

Toll Free: 888.812.1516 ● Web: [surroundair.com](http://surroundair.com)  
Email: [support-team@surroundair.com](mailto:support-team@surroundair.com)



# WARNINGS

**Failure to comply with the warnings listed below may result in electric shock or serious injury.**

This product should be used only in accordance with the specifications outlined in this manual. Usage other than what has been specified here may result in serious injury.

When using electrical appliances, basic precautions should always be followed to reduce the risk of fire, electric shock and injury to persons, including the following:

- Read all instructions before using this appliance.
- **IMPORTANT** - This appliance has a polarized plug (one blade is wider than the other). To reduce the risk of electric shock, this plug is intended to fit in a polarized outlet only one way. If the plug does not fit fully in the outlet, reverse the plug. If it still does not fit, contact a qualified electrician. Do not attempt to circumvent this safety feature.
- To avoid fire or shock hazard, plug the appliance directly into a proper AC electrical outlet.
- Keep the cord out of heavy traffic areas. To avoid fire hazard, NEVER put the cord under rugs, or near heat registers, radiators, stoves or heaters.
- To protect against electrical hazards, DO NOT immerse in water or other liquids. Do not use near water.
- Children cannot recognize the hazards associated with the usage of electrical appliances. For this reason, always supervise children when they are near the unit.
- Always unplug the air purifier before moving it, opening the grill, changing filters, cleaning or whenever the air purifier is not in use. Be sure to pull by the plug and not by the cord.
- NEVER drop or insert any object into any openings.
- DO NOT run cord under carpeting.
- DO NOT cover cord with throw rugs, runners, or similar coverings.
- DO NOT route cord under furniture or appliances. Keep the cord out of traffic areas and where it will not be tripped over.
- DO NOT operate any appliance with a damaged cord or plug. If the fan motor fails to rotate after the appliance malfunctions, or if it has been dropped or damaged in any manner, contact Surround Air Customer Service for assistance.
- Use this appliance only for intended household use as described in this manual. Any other use not recommended by the manufacturer may cause fire, electric shock or injury to persons.
- DO NOT use outdoors.
- DO NOT place anything on top of unit.
- NEVER block the air openings, grills/outlets or place on a soft surface such as a bed or sofa. This could cause the unit to tip over, blocking the air intake or outlet opening.
- DO NOT attempt to repair or adjust any electrical or mechanical functions on this unit. Doing so will void your warranty. The inside of the unit contains no user serviceable parts. All servicing should be performed by qualified personnel only.
- DO NOT use in places where flammable and explosive materials are stored.
- DO NOT stare directly at the UV lamp when glowing. Do not place your face against the front or rear grill when in operation.
- **WARNING:** To reduce the risk of fire or electric shock, do not use this fan with any solid-state speed control device.

## TECHNICAL SPECIFICATIONS

Rated Voltage:	AC 120V, 60Hz
Rated Power:	60W
Fan Speed:	100 cfm
Weight:	9.12 lbs.
Dimensions:	24.5" (H) x 8" (W) x 11" (D)
Coverage Area:	Up to 400 sq. ft.

## AIR CLEANING FUNCTIONS

The Surround Air T1000 offers multiple air-cleaning technologies to remove nearly all types of airborne contaminants.

**HEPA FILTER:** The most effective type of filter for capturing fine dust and allergen particles, such as pollens, dust mites and mold spores.

**ACTIVATED CARBON FILTER:** The most effective type of filter for removing chemicals, gases, odors and smoke.

**UV-C LIGHT:** Destroys micro-organisms such as germs, viruses, bacteria and fungi.

**PHOTOCATALYTIC OXIDATION:** Effectively reduces chemicals, bacteria and odors.

**IONIZATION:** Circulates air-cleaning ions, settling pollutants out of the air and improving the efficiency of the filters.

## DIAGRAM - EXTERNAL

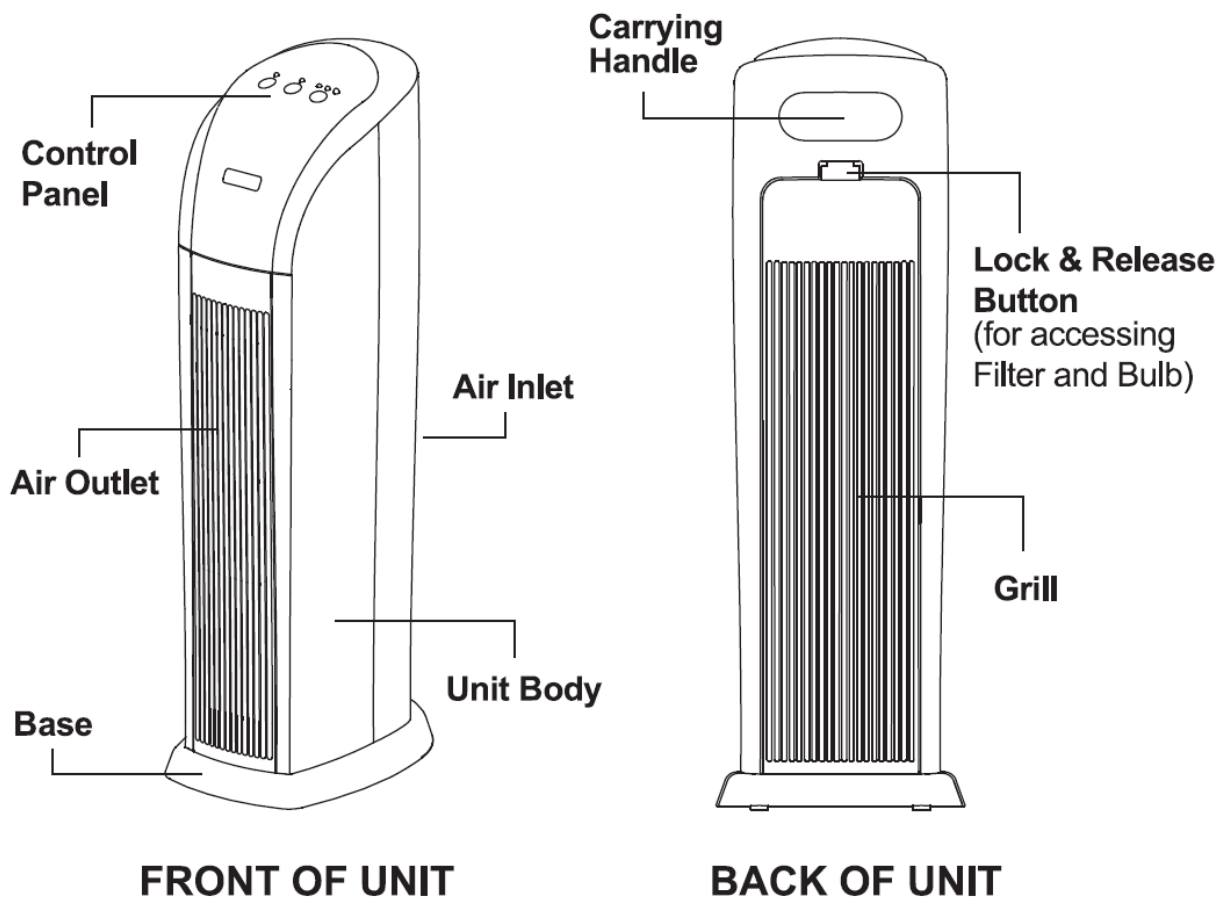

# DIAGRAM - INTERNAL

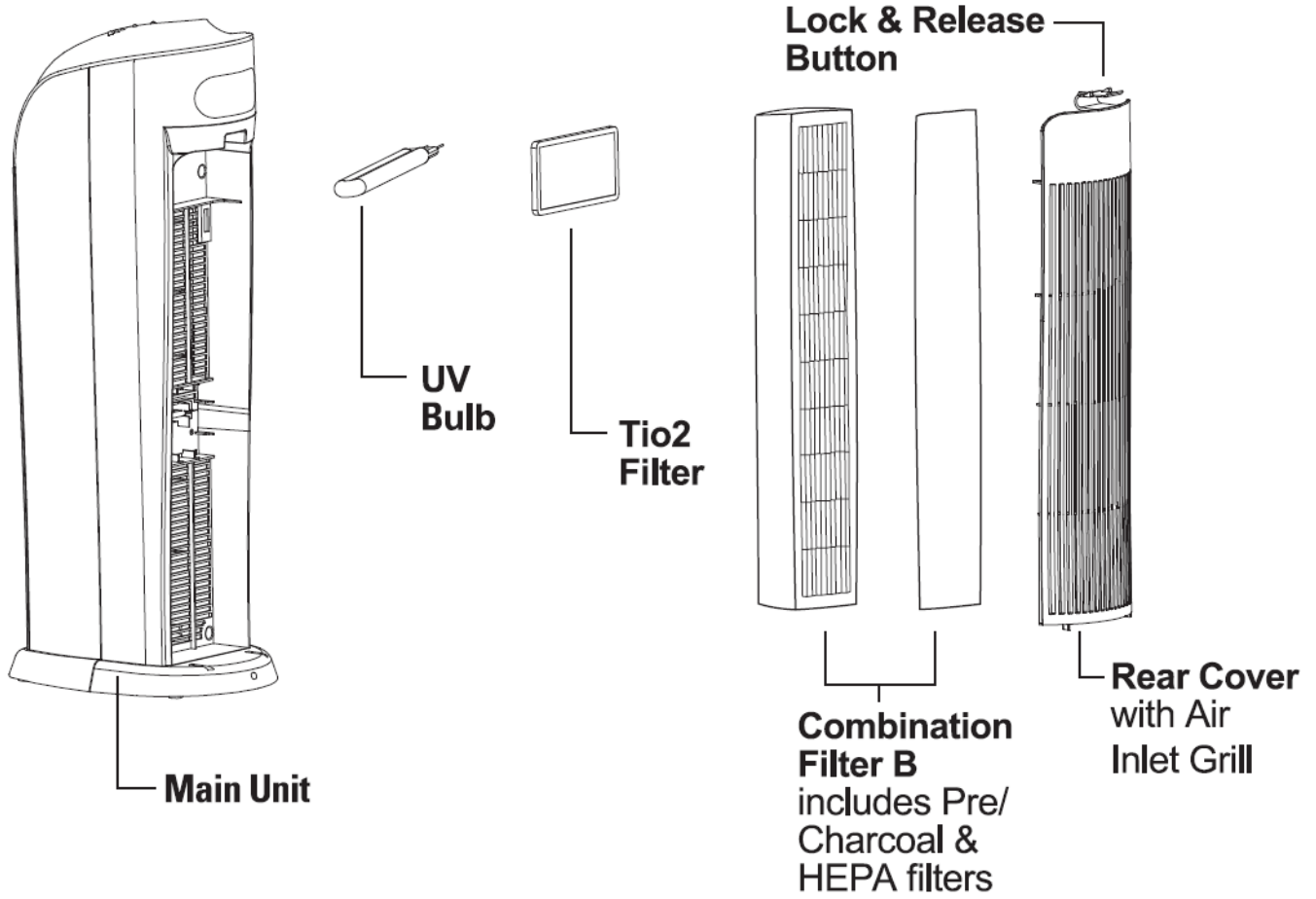

# CONTROL PANEL

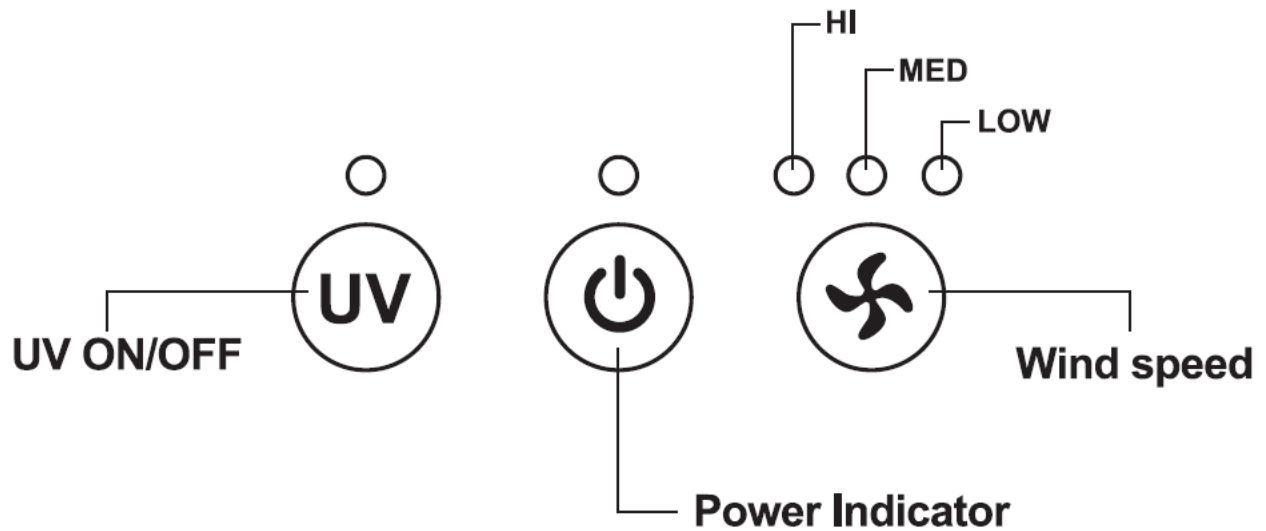

---

## OPERATING INSTRUCTIONS

### Before Operating the Air Purifier

1. Set the air purifier on a firm, level surface.
  2. To ensure proper air flow, place the air purifier at least one foot from any wall or furniture.
  3. Make sure none of the grills are blocked.
  4. Plug the power cord into a wall outlet (100-120V AC).
- IMPORTANT:** When moving the air purifier, always lift the unit by the carrying handle located on the back.

### How to Start

After plugging the air purifier into a proper socket, the red indicator will be lit. Press the Power button to turn the unit on. The indicator light will then turn green. Press the button again to turn the unit off.

### Fan Modes

Press the Fan button to switch the fan speed between Low, Medium and High. The LED lights will indicate which mode the fan is set to.

### UV Option

Press the UV button to turn the UV lamp on and off. When the UV indicator is lit, it is turned on.

---

## CLEANING AND MAINTAINING THE COMBINATION FILTER

The T1000 combination filter should be cleaned about once a month.

1. Remove the combination filter through the back of the air purifier.
2. Separate the Carbon filter from the HEPA filter.
3. Use the hand attachment of your vacuum to remove the dust and debris from both filters. Clean both sides of each filter.
4. Re-attach the Carbon filter to the HEPA filter and put back into the unit. Resume normal operation.

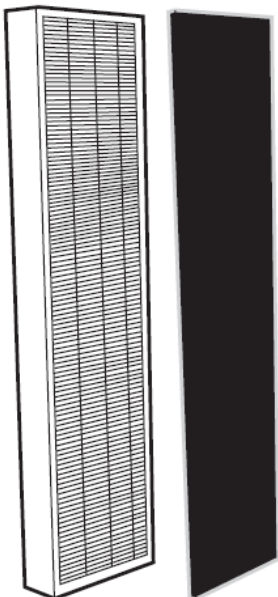

Filter Package includes:

**1-Piece HEPA Filter**

**1-Piece Pre-/Charcoal Filter**



**Create ONE  
COMPLETE  
COMBINATION  
FILTER**

## CHANGING THE COMBINATION FILTER

### When to Change

In most cases, the filter should be changed when the **Change Filter Indicator** begins to flash, where the green power light turns red and flashes continuously. This occurs after the air purifier has run a certain number of total hours since the last reset, based on what is typically the best time to change it. This is just a general guideline though. In some cases, such as in unusually high-pollution environments, the filter should be changed more frequently than this. In other cases, it will last longer than the Change Filter Indicator recommends. The best way to determine this is by the color and condition of the HEPA side of the filter, which is the white, pleated side. If it is still fairly bright-white in color, then this is a sign the filter still has useful life remaining. If it is dingy brown or gray, even after hand vacuuming the visible debris on it, then it should be replaced.

### Replacing the Filter

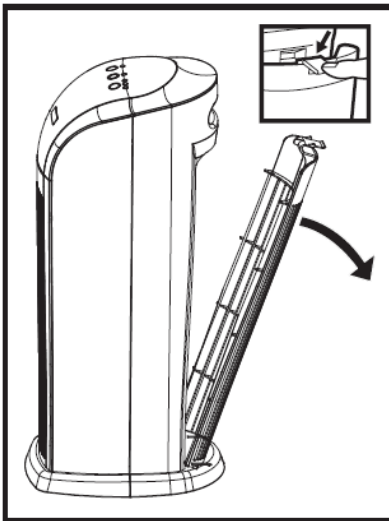

1. Turn off and unplug the unit.
2. Press the Lock & Release Button and remove the rear cover.

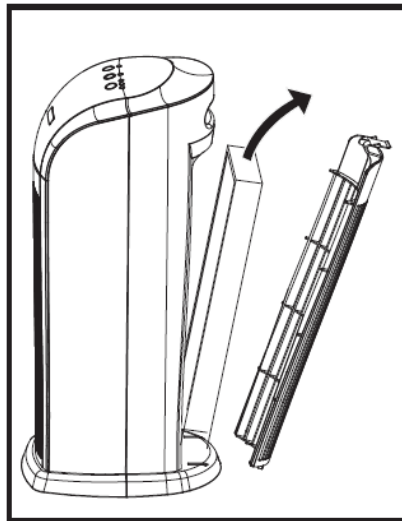

3. Remove the used Combination Filter

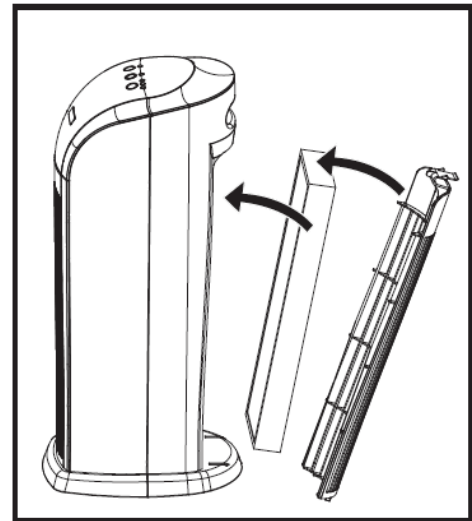

4. Insert the new Filter into the unit. Follow the arrow on the filter for the correct direction.
5. Reattach the front cover, securely latching into place.

## INSTALLING & REMOVING THE UV LAMP

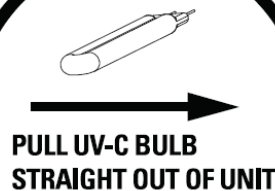
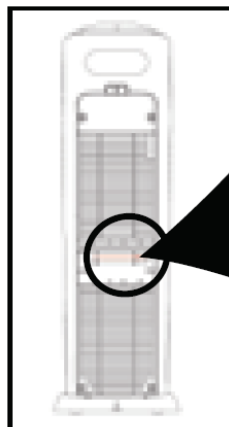
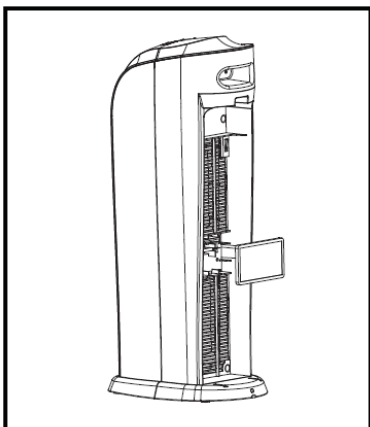

The UV lamp is held in place by four screws. To change, simply remove the screws, remove the lamp, put the new one in, and then tighten the screws back into place. The Photocatalytic (TiO<sub>2</sub>) filter in front of the lamp only needs to be replaced if it shows significant corrosion.

# Warranty

**What is covered:** All parts defective in material and workmanship.

**Exclusions:** Regular replacement parts such as air filter cartridges and UV lamps.

**For how long:** Three years from purchase date.

**What we will do:** Repair or replace any defective parts.

**What you must do:**

1. Go to the following web address and fill out the form located on this page:  
[www.surroundair.com/return-form/](http://www.surroundair.com/return-form/)
2. After receiving your shipping instructions, pack the product in its original carton, and in the same manner in which you received it, or as identical as possible.
3. Include proof of purchase inside box.
4. Label and ship the unit, freight prepaid, to the address provided.

## Other Conditions

The provisions of this warranty are in lieu of any other written warranty, whether express or implied, written or oral, including any warranty of merchantability or fitness for a particular purpose. The manufacturer's maximum liability shall not exceed the actual purchase price paid by you for the product. In no event shall the manufacturer be liable for special, incidental, consequential, or indirect damages. This warranty does not cover a defect that resulted from improper or unreasonable use or maintenance, accident, improper packing, or unauthorized tampering, alteration, or modification as determined solely by us. This warranty is void if the label bearing the serial number has been removed or defaced.

## 90-Day Replacement Policy

If any part requires repair during the first 90 days after receiving your air purifier, due to manufacturer defect, then Surround Air will replace it with a new machine.

**What you must do:**

1. Go to the following web address and fill out the form located on this page:  
[www.surroundair.com/return-form/](http://www.surroundair.com/return-form/)
2. After receiving your shipping instructions, pack the product in its original carton, and in the same manner in which you received it, or as identical as possible.
3. Include proof of purchase inside box.
4. Label and ship the unit, freight prepaid, to the address provided.

## Spare Parts

1. HEPA/Activated Carbon Air Filter Cartridge
2. Germicidal UV Lamp

## Where to Buy

Surround Air

<http://www.surroundair.com>

Toll Free: 888.812.1516



Surround Air  
Div. of Indoor Purification Systems LLC  
334 Marshall Way, Suite C  
Layton, UT 84041

SurroundAir.com  
support-team@surroundair.com

Toll Free: 888.812.1516